

MAX14870/MAX14872

Compact 4.5V to 36V Full-Bridge DC Motor Drivers

General Description

The MAX14870/MAX14872 motor drivers provide a small, low-power and simple solution for driving and controlling brushed DC motors and relays with voltages between 4.5V and 36V. Very low driver on-resistance reduces power dissipation.

These drivers feature a charge-pump-less design for reduced external components and low supply current. Integrated fast-decay current regulation allows user-adjustable peak startup motor currents and requires minimal external components.

A separate voltage-sense input (SNS) reduces current sensing errors due to parasitic trace resistance.

The MAX14870/MAX14872 features shoot-through protection and internal free-wheeling diodes that absorb inductive motor currents. Driver outputs are short-circuit-protected from shorts to ground, to the supply, and between M1 and M2. An active-low $\overline{\text{FAULT}}$ output signals thermal overload and overcurrents during fault conditions.

The MAX14870 has PWM and direction-control inputs, while the MAX14872 has forward and reverse inputs for direction control. See the [Function Tables](#).

The MAX14870/MAX14872 are available in a 12-pin (3mm x 3mm) TDFN-EP package and operate over the -40°C to $+85^{\circ}\text{C}$ temperature range.

Typical Application Circuit

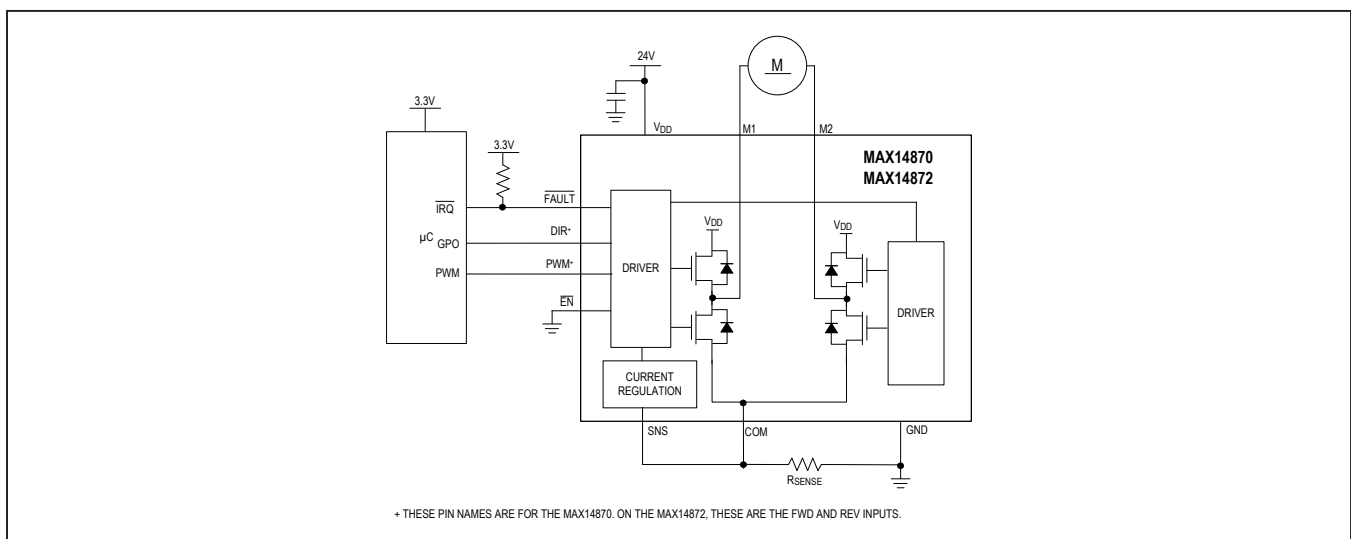

Benefits and Features

- Small Package Handles High Power and Reduces Footprint Circuit Size
 - Up to 2.5A Peak Motor Current
 - Space-Saving TDFN-EP (3mm x 3mm) Package
 - Flexible 4.5V–36V Supply Enables Longer Runtime on Batteries
- Low Power Consumption Runs Cooler and Longer
 - 280mΩ (typ) Total Bridge On-Resistance
 - 1mA (typ) Supply Current at 30kHz/24V
 - 10µA (max) Standby Current at 12V
- Simplified Designs Reduces Time to Market
 - Charge-Pump-Less Architecture
 - Current Regulation Only Requires a Sense Resistor
 - Current-Sense Input Simplifies PCB Layout
- Integrated Protection Provides Robust Driving Solution
 - Short-Circuit-Protected Drivers
 - Thermal-Shutdown Undervoltage Lockout
 - Diagnostic $\overline{\text{FAULT}}$ Output
 - -40°C to $+85^{\circ}\text{C}$ Temperature Range

Applications

- Printers and Scanners
- Relay Drivers
- Vending and Gaming Machines

[Ordering Information](#) appears at end of data sheet.

Absolute Maximum Ratings

(All voltages referenced to GND.)

V _{DD}	-0.3V to +40V
M1, M2	-0.3V to (V _{DD} + 0.3V)
PWM, DIR, FWD, REV, FAULT, EN, SNS	-0.3V to +6.0V
COM	-0.3V to +0.3V
Continuous Current Into M1, M2	±3A
Continuous Power Dissipation (T _A = +70°C)	
Single-Layer Board (derate at 15.9mW/°C	
above +70°C).....	1270mW

Multilayer Board (derate at 24.4mW/°C

above +70°C).....	1951mW
Operating Temperature Range.....	-40°C to +85°C
Junction Temperature.....	+150°C
Storage Temperature Range.....	-65°C to +150°C
Lead Temperature (soldering, 10s)	+300°C
Solder Temperature (reflow)	+260°C

Stresses beyond those listed under "Absolute Maximum Ratings" may cause permanent damage to the device. These are stress ratings only, and functional operation of the device at these or any other conditions beyond those indicated in the operational sections of the specifications is not implied. Exposure to absolute maximum rating conditions for extended periods may affect device reliability.

Package Thermal Characteristics (Note 1)

Junction-to-Case Thermal Resistance (θ _{JC})	
TDFN-EP (Single-Layer Board).....	8.5°C/W
TDFN-EP (Multilayer Board).....	8.5°C/W

Junction-to-Ambient Thermal Resistance (θ _{JA})	
TDFN-EP (Single-Layer Board).....	63°C/W
TDFN-EP (Multilayer Board).....	41°C/W

Note 1: Package thermal resistances were obtained using the method described in JEDEC specification JESD51-7, using a four-layer board. For detailed information on package thermal considerations, refer to www.maximintegrated.com/thermal-tutorial.

Electrical Characteristics

(V_{DD} = 4.5V to 36V, T_A = T_{MIN} to T_{MAX}, unless otherwise noted. Typical values are at V_{DD} = 12V, T_A = +25°C) (Note 2)

PARAMETER	SYMBOL	CONDITIONS	MIN	TYP	MAX	UNITS
POWER SUPPLY						
Supply Voltage	V _{DD}		4.5		36	V
Supply Current	I _{DD}	EN = low, M1/M2 not connected	f _{PWM/FWD} = 50kHz	1		mA
			No switching	0.5	1.2	
Shutdown Supply Current	I _{SHDN}	EN = high, driver is in shutdown	V _{DD} = 12V	3.7	10	µA
			V _{DD} = 36V	10	20	
Undervoltage Lockout Threshold	V _{UVLO}	V _{DD} rising	3.3	3.8	4.3	V
Undervoltage Lockout Threshold Hysteresis	V _{UVLO_HYST}			400		mV

Electrical Characteristics (continued)(V_{DD} = 4.5V to 36V, T_A = T_{MIN} to T_{MAX}, unless otherwise noted. Typical values are at V_{DD} = 12V, T_A = +25°C) (Note 2)

PARAMETER	SYMBOL	CONDITIONS	MIN	TYP	MAX	UNITS
DRIVER (M1, M2)						
Driver Output Resistance (High Side + Low Side)	R _{ON}	I _{M_} = 2.5A	T _J = +25°C	280	395	mΩ
			T _J = +125°C	410	580	
Driver Overload Current Limit	I _{M_OL}		3			A
M1, M2 Leakage Current	I _{M_LKG}	$\overline{\text{EN}}$ = High, V _{M1} = V _{M2} = 0V or V _{DD}	-1		+1	μA
M1, M2 Body Diode Forward-Voltage	V _{BF}	Low-side diode, $\overline{\text{EN}}$ = high, I _F = 2.5A			1.5	V
		High-side diode, $\overline{\text{EN}}$ = high, I _F = 2.5A			1.5	
CURRENT REGULATION (SNS, COM)						
SNS Current Sense Threshold	V _{SNS_TH}	V _{SNS} rising (Note 3)	94	100	110	mV
SNS Input Leakage Current	I _{SNS_LKG}	V _{SNS} = ±250mV	-1		+1	μA
COM Leakage Current	I _{COM_LKG}	$\overline{\text{EN}}$ = high, V _{COM} = ±250mV	-1		+1	μA
LOGIC SIGNALS (PWM, DIR, FWD, REV, $\overline{\text{EN}}$, $\overline{\text{FAULT}}$)						
Input Logic-High Voltage	V _{IH}	FWD, REV, PWM, DIR	2			V
Input Logic-Low Voltage	V _{IL}	FWD, REV, PWM, DIR			0.8	V
$\overline{\text{EN}}$ Input Logic-High Voltage	V _{EN_IH}		1.6			
$\overline{\text{EN}}$ Input Logic-Low Voltage	V _{EN_IL}				0.4	
Input Leakage Current	I _{IL}	PWM, DIR, FWD, REV, $\overline{\text{EN}}$, V _{INPUT} = 5.5V or 0V	-1		+1	μA
$\overline{\text{FAULT}}$ Output Low Voltage	V _{OL}	$\overline{\text{FAULT}}$ asserted, I _{SINK} = 5mA			0.5	V
$\overline{\text{FAULT}}$ Off Leakage Current	I _{F_LKG}	$\overline{\text{FAULT}}$ deasserted, V _{FAULT} = 5.5V	-1		+1	μA
PROTECTION						
Thermal-Shutdown Threshold	T _{SHDN}	Temperature rising, $\overline{\text{FAULT}}$ asserted		+160		°C
Thermal-Shutdown Hysteresis	T _{SHDN_HYST}			10		°C

AC Electrical Characteristics(V_{DD} = 4.5V to 36V, T_A = T_{MIN} to T_{MAX}, unless otherwise noted. Typical values are at V_{DD} = 12V, T_A = +25°C) (Note 2)

PARAMETER	SYMBOL	CONDITIONS		MIN	TYP	MAX	UNITS
PWM Frequency	f _{SW}	$\overline{\text{EN}}$ = low	MAX14870, switching signal applied at PWM			50	kHz
			MAX14872, switching signal applied at FWD or REV			50	
Dead Time	t _{DEAD}				140		ns
M1, M2 Slew Rate	SR				200		V/μs
M1, M2 High-Side Propagation Delay	t _{PR}	R _L = 1kΩ, C _L = 50pF, PWM/FWD/DIR/REV rising, Figure 1			620		ns
M1, M2 Low-Side Propagation Delay	t _{PF}	R _L = 1kΩ, C _L = 50pF, PWM/FWD/DIR/REV falling, Figure 1			583		ns
Current Regulation Fixed Off-Time	t _{OFF}	PWM/FWD = high, $\overline{\text{EN}}$ = low, V _{SNS} > V _{SNS_TH}		7.8	15	22	μs
Current Regulation Minimum On-Time	t _{CR_BL}	PWM/FWD = high, $\overline{\text{EN}}$ = low, V _{SNS} > V _{SNS_TH}			2.5		μs
Overcurrent Blanking Time	t _{OC_BL}	M1/M2 is shorted to V _{DD} or GND, Figure 2			1		μs
Overcurrent Autoretry Timeout	t _{OC_TO}	PWM/FWD = high, $\overline{\text{EN}}$ = low, I _M or I _{M2} > I _{M_OL} , Figure 2			2		ms
Enable Turn-On Delay	t _{EN_ON}	PWM/FWD = high, R _L = 1kΩ, C _L = 50pF, $\overline{\text{EN}}$ falling, M1/M2 rising to 10%, Figure 3			23		μs
Enable Turn-Off Delay	t _{EN_OFF}	PWM/FWD = high, R _L = 1kΩ, C _L = 50pF, $\overline{\text{EN}}$ rising, M1/M2 falling to 90%, Figure 3			50		μs

Note 2: All units are production tested at T_A = +25°C. Specifications over temperature are guaranteed by design.**Note 3:** V_{SNS_TH} is the threshold voltage to turn on current regulation.

Test Circuits/Timing Diagrams

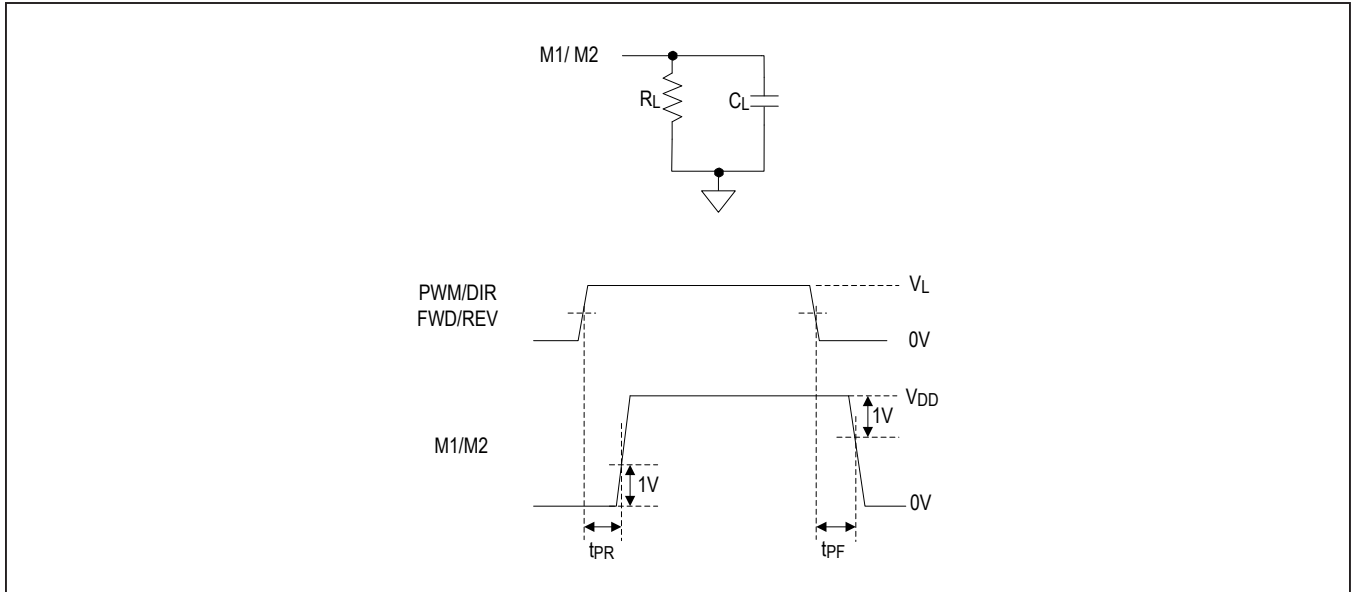

Figure 1. M1/M2 Propagation Delay

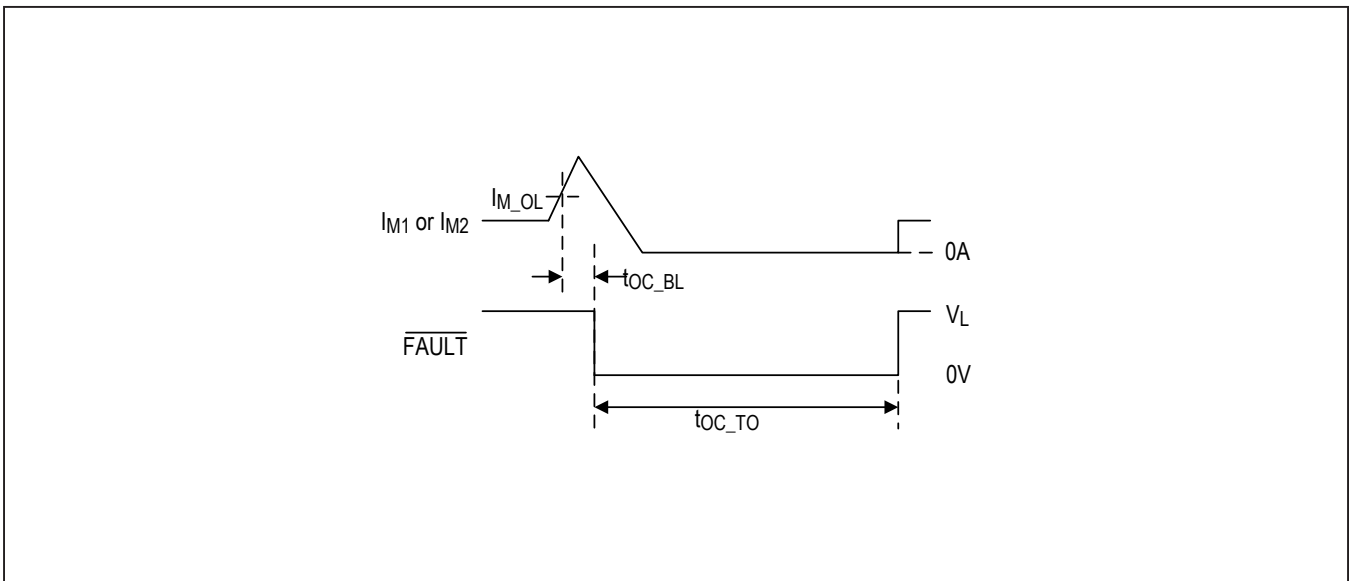

Figure 2. Overcurrent Autoretry Timeout

Test Circuits/Timing Diagrams (continued)

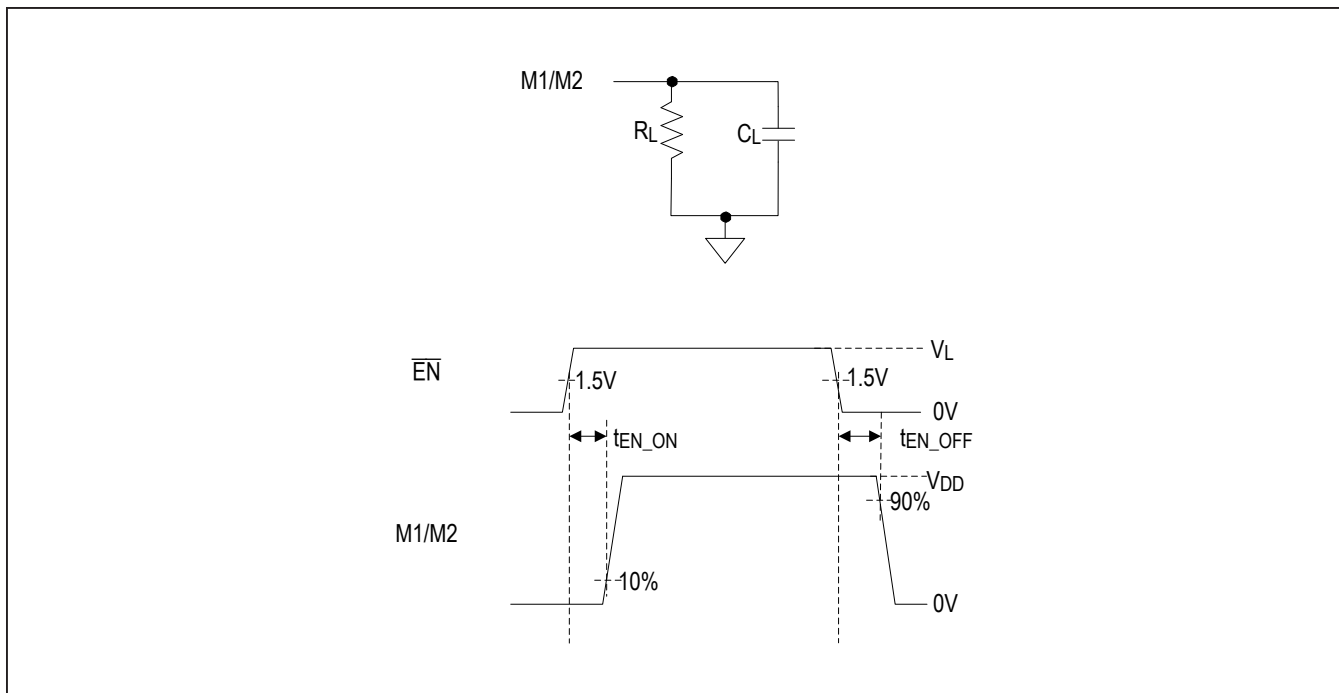
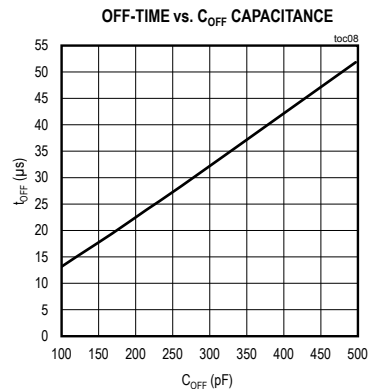
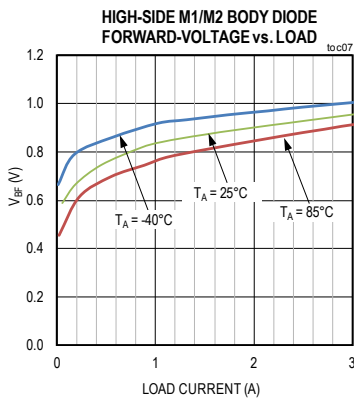
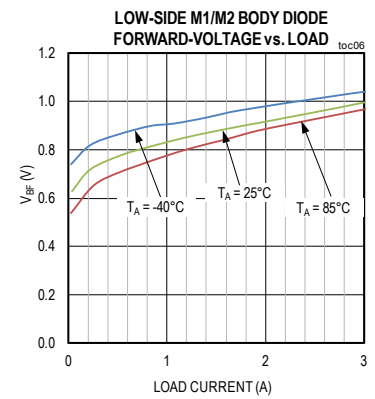
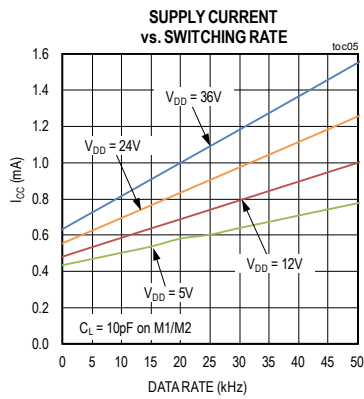
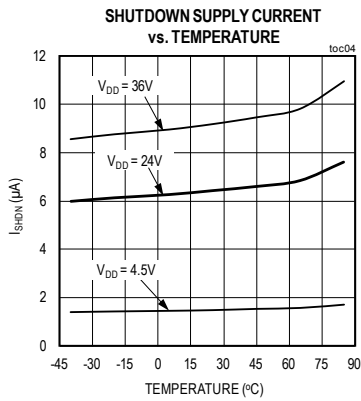
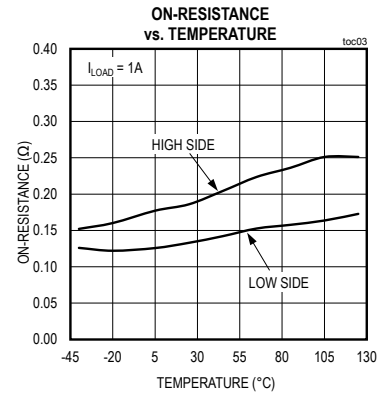
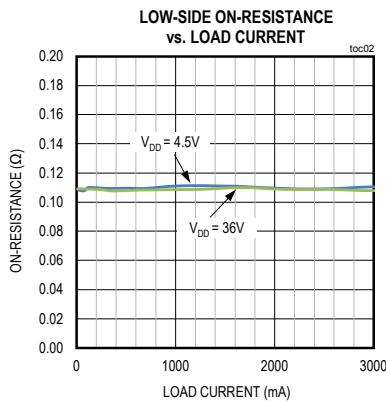
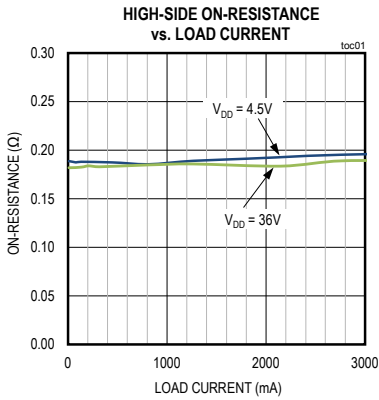

Figure 3. Enable/Disable Delays

Typical Operating Characteristics

($V_{DD} = 12V$, $T_A = +25^\circ C$, unless otherwise noted.)



Pin Configuration

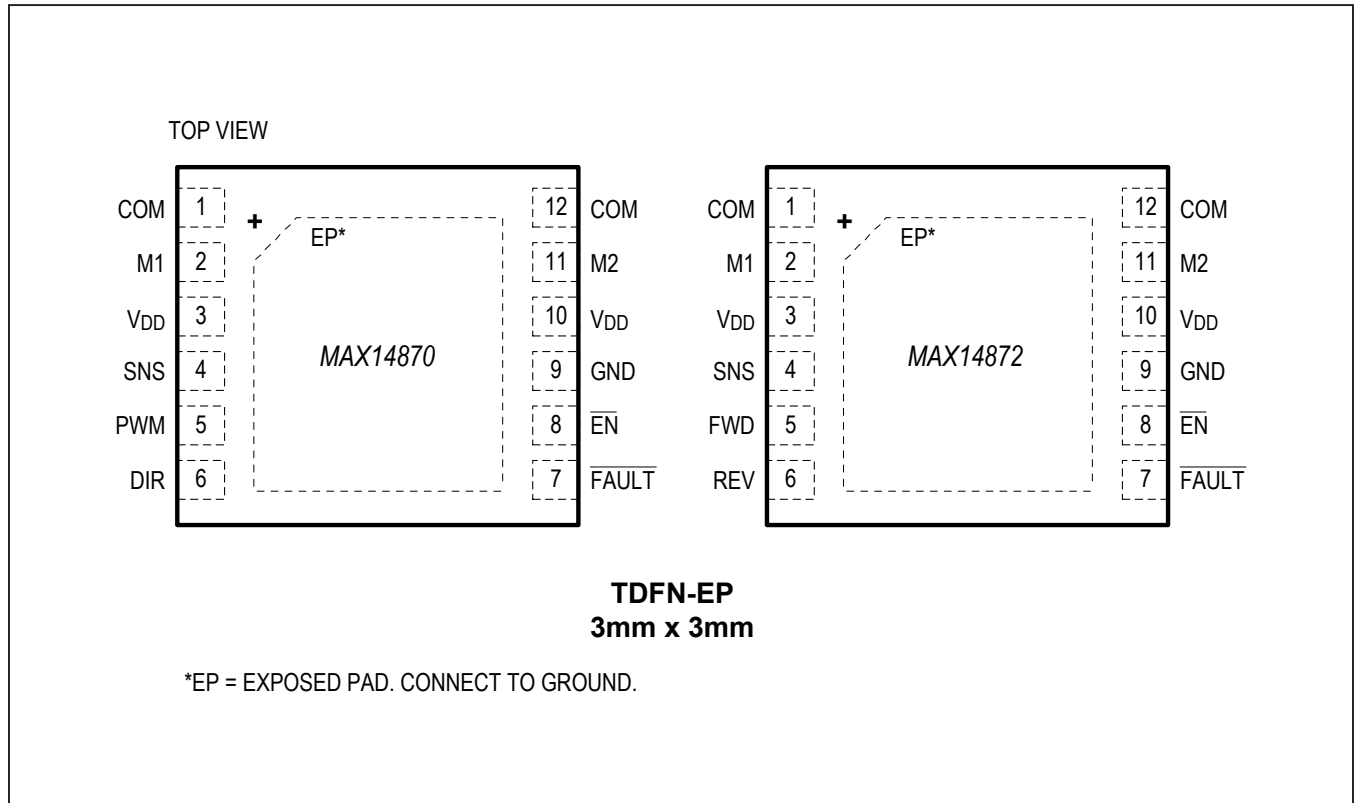

Pin Description

PIN		NAME	FUNCTION
MAX14870	MAX14872		
1, 12	1, 12	COM	COM Current Output. Connect a sense resistor (R_{SENSE}) from COM to GND to use internal current regulation and/or external current control. Connect both COM pins together.
2	2	M1	Motor Driver Output 1. See the Function Tables for more information.
3, 10	3, 10	V_{DD}	Power Supply Input. Bypass V_{DD} to GND with a 1 μ F ceramic capacitor as close to the device as possible. Connect both V_{DD} pins together.
4	4	SNS	Current Sense Input. Connect SNS to COM to enable current regulation. To bypass current regulation, connect SNS to GND.
5	—	PWM	PWM Control Logic Input. PWM and DIR control M1 and M2 on the MAX14870. See the Function Tables for more information.
6	—	DIR	Direction Control Logic Input. PWM and DIR control M1 and M2 on the MAX14870. See the Function Tables for more information.
—	5	FWD	Forward Control Logic Input. FWD and REV control M1 and M2 on the MAX14872. See the Function Tables for more information.
—	6	REV	Reverse Control Logic Input. FWD and REV control M1 and M2 on the MAX14872. See the Function Tables for more information.

Pin Description (continued)

PIN		NAME	FUNCTION
MAX14870	MAX14872		
7	7	$\overline{\text{FAULT}}$	Open-Drain Active-Low Fault Output. $\overline{\text{FAULT}}$ goes low during an overcurrent condition and thermal shutdown.
8	8	$\overline{\text{EN}}$	Active-Low Enable Input. Drive $\overline{\text{EN}}$ low to enable the driver outputs. Drive $\overline{\text{EN}}$ high to three-state the driver outputs.
9	9	GND	Ground
11	11	M2	Motor Driver Output 2. See the MAX14870 Function Table and MAX14872 Function Table for more information.
—	—	EP	Exposed Pad. Connect to ground.

MAX14870 Function Table

INPUTS				OUTPUTS		OPERATING MODE
$\overline{\text{EN}}$	V_{SNS}	PWM	DIR	M1	M2	
1	X	X	X	High impedance	High impedance	Shutdown
0	$< V_{\text{SNS_TH}}$	0	X	GND	GND	Brake
0	$< V_{\text{SNS_TH}}$	1	0	GND	V_{DD}	Counterclockwise/reverse
0	$< V_{\text{SNS_TH}}$	1	1	V_{DD}	GND	Clockwise/forward
0	$> V_{\text{SNS_TH}}$	1	0	Switching	Switching	Current regulation
0	$> V_{\text{SNS_TH}}$	1	1	Switching	Switching	Current regulation

X = Don't care.

MAX14872 Function Table

INPUTS				OUTPUTS		OPERATING MODE
$\overline{\text{EN}}$	V_{SNS}	FWD	REV	M1	M2	
1	X	X	X	High impedance	High impedance	Shutdown
0	$< V_{\text{SNS_TH}}$	0	0	GND	GND	Brake
0	$< V_{\text{SNS_TH}}$	1	0	V_{DD}	GND	Forward
0	$< V_{\text{SNS_TH}}$	0	1	GND	V_{DD}	Reverse
0	$< V_{\text{SNS_TH}}$	1	1	High impedance	High impedance	Three-state
0	$> V_{\text{SNS_TH}}$	1	0	Switching	Switching	Current regulation
0	$> V_{\text{SNS_TH}}$	0	1	Switching	Switching	Current regulation

X = Don't care.

Functional Diagrams

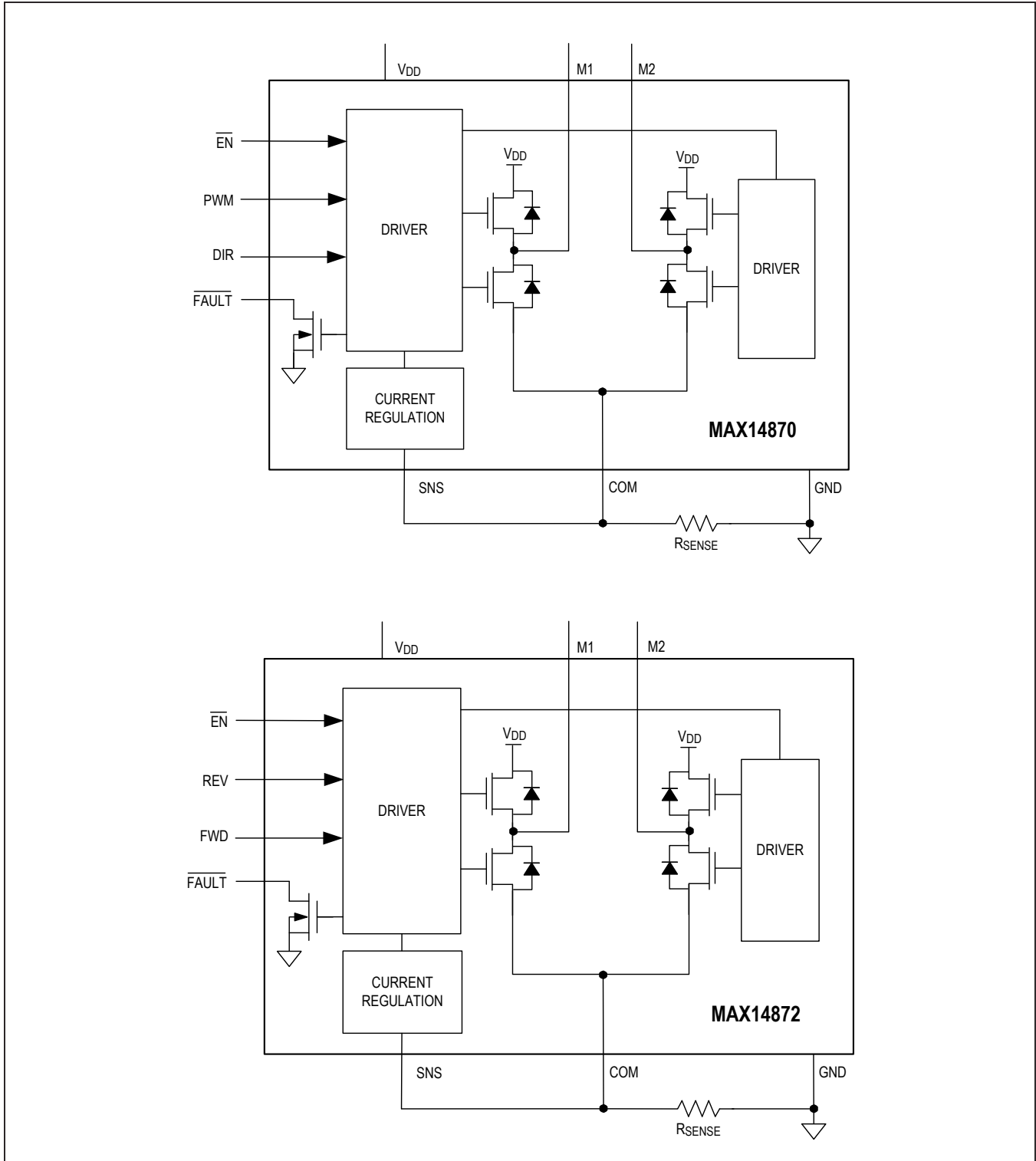

Detailed Description

The MAX14870/MAX14872 DC brushed motor drivers provide a low-power and flexible solution for driving and controlling brushed motors with voltages between 4.5V and 36V. Peak motor currents of up to 2.5A ensure large motor torque that is controllable by an external PWM signal and/or by autonomous internal current regulation.

The MAX14870 has PWM and direction-control inputs, while the MAX14872 has forward and reverse inputs for direction control. See the [MAX14870 Function Table](#) and [MAX14872 Function Table](#).

Charge-pump-less design requires minimal external components and low supply current.

Integrated current regulation allows limiting peak start-up motor currents. Shoot-through protection with a 140ns (typ) dead time ensures low operating current. Internal free-wheeling diodes absorb inductive motor currents. The $\overline{\text{FAULT}}$ output signals thermal overload and overcurrents.

Overcurrent Protection

The MAX14870/MAX14872 are protected against shorts on M1/M2 to any voltage between V_{DD} and GND, including shorts to GND, V_{DD} , and between M1 and M2 via overcurrent limiting. When a current above 6A (typ) flows through M1 or M2 for longer than 1 μ s, an overcurrent condition is detected and the H-bridge drivers are automatically disabled and the $\overline{\text{FAULT}}$ output asserts.

If the overcurrent condition continues for longer than the overcurrent autoretry timeout (2ms (typ)) the MAX14870/MAX14872 enters autoretry mode. In autoretry mode, the M1 and M2 outputs are re-enabled for 1 μ s (typ) and $\overline{\text{FAULT}}$ goes high-impedance. The drivers are disabled again and $\overline{\text{FAULT}}$ is re-asserted if the overcurrent condition persists.

PWM Control (MAX14870 Only)

The PWM input is used for motor speed/torque control. Increasing or decreasing the duty cycle at PWM sets the effective (average) voltage across the motor terminals and allows first-order speed control.

When PWM is logic-high, the motor is driven in the direction defined by DIR. When PWM is logic-low, the bridge is in brake mode. In brake mode, the motor current

continues flowing and recirculates through the low-side transistors of the H-bridge driver, due to its inductive impedance and back EMF.

FWD/REV Control (MAX14872 only)

The FWD input is used to drive the motor forward/turn a relay on. The REV input reverses the M1 and M2 polarity, to drive the motor in reverse/turn a relay off.

FWD/REV control can be optionally used to implement either bipolar motor control (with both M1 and M2 switching) or unipolar control, where only M1 or M2 switches.

Slope Control

The MAX14871 drivers turn-on and turn-off with active slope-control during the M1/M2 transition times. The integrated slew rate-limiting reduces EMC (like conducted and radiated EMI) associated with high di/dt rates.

Thermal Shutdown

The MAX14870/MAX14872 include integrated protection against thermal overload. When the junction temperature exceeds 160°C (typ), the H-bridge is three-stated, M1 and M2 are disabled, and $\overline{\text{FAULT}}$ is asserted.

If the motor was spinning before thermal shutdown occurred, the motor's inductance will push current through the internal M1 and M2 diodes, forcing the motor into fast decay, with a voltage across its terminals of V_{DD} .

M1 and M2 are automatically reenabled when the junction temperature falls to 150°C (typ).

Current Sensing

Connect a sense resistor (R_{SENSE}) between COM and GND to monitor the motor current during operation. Select R_{SENSE} such that the voltage at COM created by motor current flowing through the sense resistor is limited to within 250mV relative to GND ($-250\text{mV} \leq V_{\text{COM}} \leq +250\text{mV}$).

Minimize series trace resistance from R_{SENSE} to GND to minimize voltage sense errors due to parasitic trace interconnect resistance. Use a star ground connection between the MAX14870/MAX14872 GND pins and the GND-side of R_{SENSE} . Connect the voltage sense close to the R_{SENSE} resistor and/or use differential voltage sensing. See [Figure 4](#).

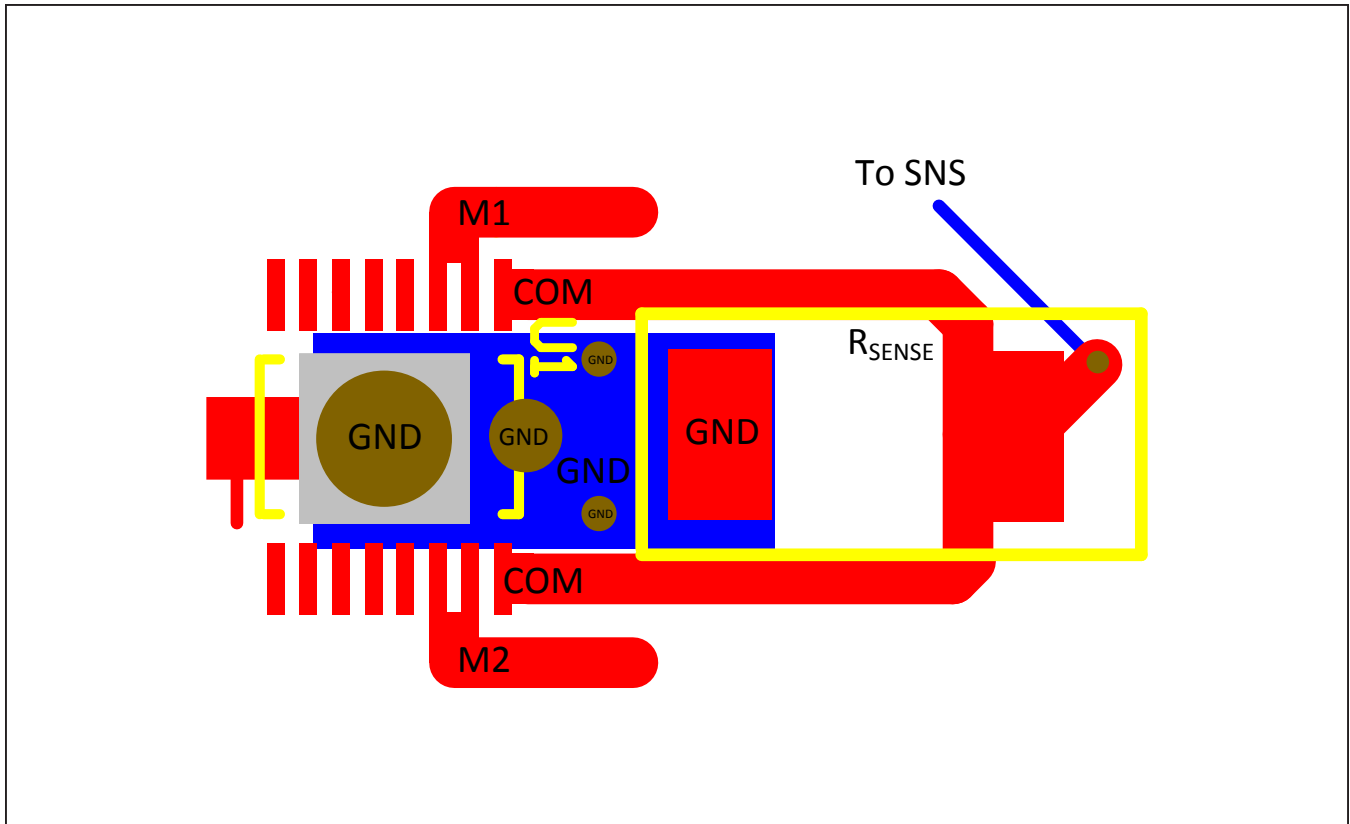

Figure 4. Layout Example for Accurate Current Sensing

Current Regulation

The MAX14870/MAX14872 features internal current regulation to limit the startup current. Regulation is set when the motor current (I_M) exceeds the current limit defined by the sense resistor (R_{SENSE}):

$$I_{M_MAX} = 0.1V/R_{SENSE}$$

When the motor current exceeds the maximum threshold, the H-bridge drive is reversed for fast decay for a fixed time ($t_{OFF} = 15\mu s$). The H-bridge is turned back to normal operation after t_{OFF} .

Fast Decay Mode

When the motor current exceeds the set threshold, the H-bridge polarity is reversed during the $15\mu s$ (typ) t_{OFF} period. This results in faster motor current decay since $-V_{DD}$ is applied across the motor’s terminals. The motor current decrease is first order with an L/R time constant and proportional to $(V_{DD} + V_{EMF})$.

Note that if t_{OFF} is larger than the motor’s L/R electrical time constant, the motor current can reverse direction, causing the motor to not start.

During fast decay, the motor’s inductive current recirculates through the external V_{DD} supply, which charges up the V_{DD} bypass capacitor. Therefore, the voltage seen across R_{SENSE} is negative during the t_{OFF} delay.

Applications Information

Layout Considerations

Connect duplicate pins (COM pins and V_{DD} pins) together with low-resistance traces. See the [Current Sensing](#) section for further layout recommendations.

Power Considerations

The MAX14870/MAX14872 driver can generate more power than the package for the device can safely dissipate. Total power dissipation for the device is calculated using the following equation:

$$P_{TOTAL} = P_{DRIVER} + P_{SW} + P_D$$

The power dissipated inside of the driver is calculated as:

$$P_{DRIVER} = I_M^2 \times R_{ON}$$

where I_M is the motor current and R_{ON} is the on-resistance of the high and low-side FETs.

P_{SW} is the power generated by the driver during the rise/fall times in switching and includes both arms of the bridge. Calculate P_{SW} using the following equation:

$$P_{SW} = I_M \times 2 \times V_{DS}$$

$$= I_M \times 2 \times (1/2 \times V_{DD} \times f_{SW} \times t_R)$$

where I_M is the motor current, t_R is the 200ns (typ) rise or fall time of the driver output, and f_{SW} is the switching frequency.

The internal diodes dissipate power during switching, as well. Calculate the power dissipated in the diodes as:

$$P_D = I_M \times 2 \times V_{BF} \times t_{DEAD} \times f_{SW}$$

Operation Without Current Regulation

To operate the MAX14870/MAX14872 without internal or external current regulation, connect SNS directly to GND. No sense resistor is required for this configuration.

Operation with External Current Regulation

The motor current can be controlled by external PWM regulation using sense resistor feedback in a control loop. To disable the internal current regulation circuitry of the MAX14870/MAX14872 and use external regulation, connect SNS directly to ground.

Note that, if fast decay control is used, the COM voltage pulses negatively when the H-bridge direction is inverted.

Use of External Capacitors

Maxim does not recommend using external capacitors across the motor terminals. Added capacitance between H-bridge outputs increases the power dissipated in the H-bridge by:

$$P_D = V_{DD}^2 \times C \times f_{SW}$$

where C is the capacitance across M1/M2 and f_{SW} is the M1/M2 switching frequency. This power is dissipated without good reason.

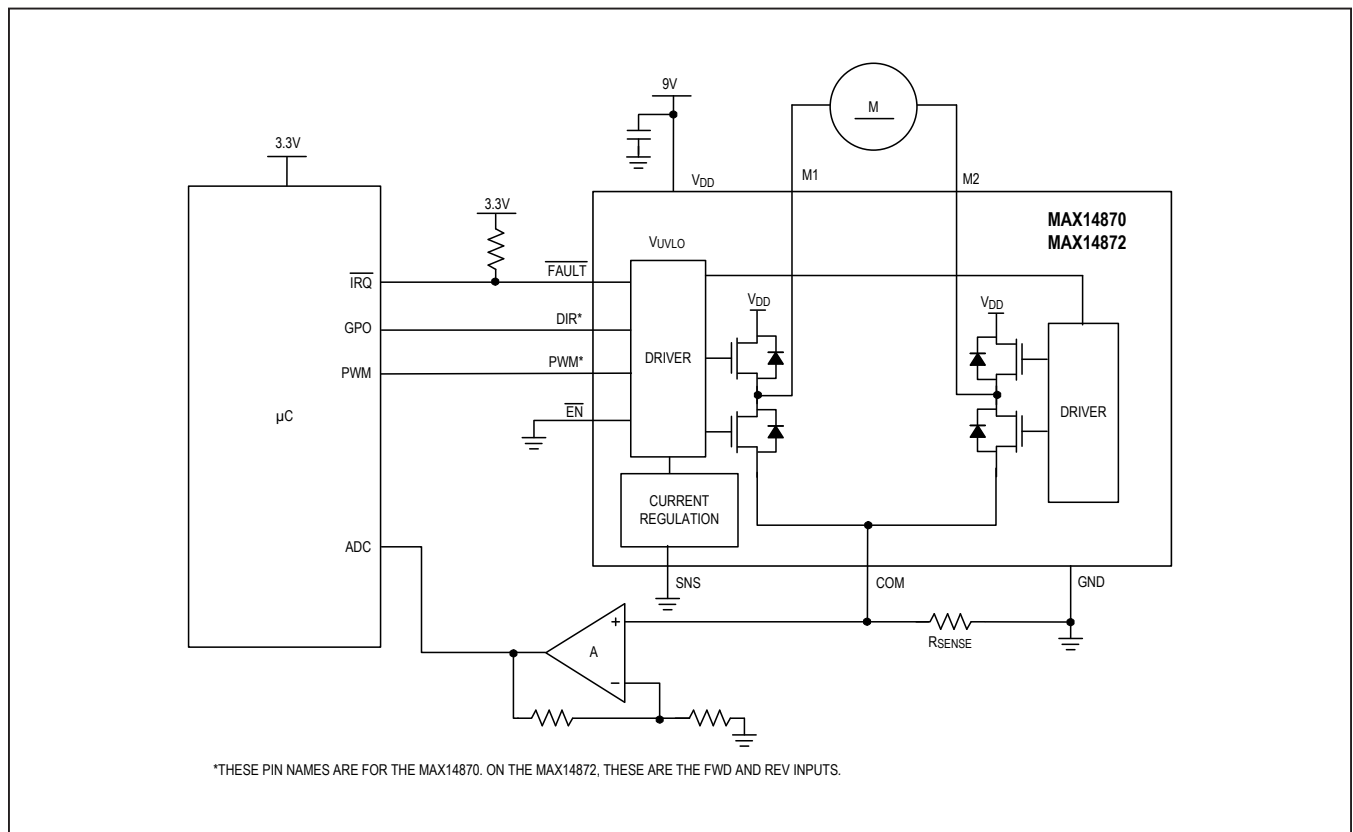

Figure 5. Operation with External Current Regulation

Ordering Information

PART	TEMP RANGE	PIN-PACKAGE
MAX14870ETC+	-40°C to +85°C	12 TDFN-EP
MAX14872ETC+	-40°C to +85°C	12 TDFN-EP

+Denotes a lead(Pb)-free/RoHS-compliant package.

*EP = Exposed pad.

Package Information

For the latest package outline information and land patterns (footprints), go to www.maximintegrated.com/packages. Note that a "+", "#", or "-" in the package code indicates RoHS status only. Package drawings may show a different suffix character, but the drawing pertains to the package regardless of RoHS status.

PACKAGE TYPE	PACKAGE CODE	OUTLINE NO.	LAND PATTERN NO.
12 TDFN-EP	TD1233+1	21-0664	90-0397

Chip Information

PROCESS: BiCMOS

Revision History

REVISION NUMBER	REVISION DATE	DESCRIPTION	PAGES CHANGED
0	9/14	Initial release	—

For pricing, delivery, and ordering information, please contact Maxim Direct at 1-888-629-4642, or visit Maxim Integrated's website at www.maximintegrated.com.

Maxim Integrated cannot assume responsibility for use of any circuitry other than circuitry entirely embodied in a Maxim Integrated product. No circuit patent licenses are implied. Maxim Integrated reserves the right to change the circuitry and specifications without notice at any time. The parametric values (min and max limits) shown in the Electrical Characteristics table are guaranteed. Other parametric values quoted in this data sheet are provided for guidance.