

NOTES

- MATERIAL:**
EMI GASKET: CONDUCTIVE ELASTOMER
CAGE: NICKEL SILVER, THICKNESS: 0.25mm
CAGE FLANGE: STAINLESS STEEL
CONNECTOR HOUSING: GLASS FILLED LIQUID CRYSTAL POLYMER (LCP), UL 94V-0, COLOR: BLACK
OVERMOLD TERMINAL HOUSING: GLASS FILLED LIQUID CRYSTAL POLYMER (LCP), UL 94V-0, COLOR: BLACK
TERMINALS: TIN BRASS
LIGHTPIPES: POLYCARBONATE, 94 V-0, CLEAR
LIGHTPIPE HOUSING: ZINC
- FINISHES:**
TERMINALS: CONTACT AREA: 0.76 MICROMETERS MINIMUM HARD GOLD OVER 1.27 MICROMETERS MINIMUM NICKEL.
COMPLIANT TAIL - MATTE TIN/LEAD OPTION: 0.76 TO 1.52 MICROMETERS 90/10 MATTE TIN-LEAD OVER 0.76 MICROMETERS MINIMUM NICKEL.
COMPLIANT TAIL - MATTE TIN OPTION: 0.76 TO 1.52 MICROMETERS MATTE TIN OVER 0.76 MICROMETERS MINIMUM NICKEL.
LIGHTPIPE HOUSING: 80 MICROMETERS MINIMUM NICKEL OVER COPPER
- REFER TO PS-75310-001 PRODUCT SPEC FOR ALL ELECTRICAL, MECHANICAL, AND ENVIRONMENTAL SPECIFICATIONS.
- LIGHTPIPE PAD LAYOUT IS FOR 0805 LOW-PROFILE LED PACKAGE, FOR OTHER RECOMMENDED LAYOUTS REFER TO MOLEX'S REPORT TS-75310-001.
- REFER TO PK-76090-0001 FOR ALL PACKAGING SPECIFICATIONS.
- THE SURFACES CONFORM TO THE MOLEX COSMETIC SPEC PS-45499-002. ALL EXTERIOR SURFACES TO BE CLASS "B" SURFACE EXCEPT THE UNDERSIDE (CLASS "C") OF THE CAGE (SIDE TOWARD THE PCB) AND AS OTHERWISE NOTED.
- THE OVERALL CAGE WIDTH AT THE VERTICAL CENTER OF THE FRONT EDGE WILL FALL WITHIN THIS DIMENSION: 14.75+/-0.30 MM. THIS PORTION OF THE CAGE WILL FLEX INWARD AS THE CAGE IS BEING INSERTED INTO THE BEZEL OPENING.
- REFER TO AS-76090-001 FOR HIGH SPEED ROUTING RECOMMENDATIONS.
- DATE CODE LOCATION IS SHOWN ABOVE.
DATE CODE FORMAT: DDDY MX A1
DDD = DAY OF THE YEAR
Y = YEAR
MX = MOLEX
A = ALPHA CHARACTER - INDICATES MANUFACTURING LINE
1 = NUMERIC CHARACTER - INDICATES PRODUCTION SHIFT
- ELASTOMERIC GASKETS ARE SUPPLIED SEPARATELY, IN THE BOX WITH THE CONNECTOR ASSEMBLIES.

PART NUMBER	DESCRIPTION - SEE VIEWS ON SHEET 2	COMPLIANT TAIL PLATING
	4 LIGHT PORTS	MATTE TIN / LEAD
	INNER 2 PORTS	MATTE TIN / LEAD
	OUTER 2 PORTS	MATTE TIN / LEAD
	4 LIGHT PORTS	MATTE TIN
	INNER 2 PORTS	MATTE TIN
	OUTER 2 PORTS	MATTE TIN
760907002	INNER 2 PORTS - ENHANCED EMI	MATTE TIN

ELASTOMERIC GASKETS SUPPLIED LOOSE IN BAGS

INITIAL RELEASE EC NO: UCP2012-1596 DRWIN:BBARKER 2011/11/16 CHKD:DMORGAN APPR:SMILLER 2011/11/28 DESCRIPTION REV: A	QUALITY SYMBOLS ∇=0 ∇=0 ∇=0	GENERAL TOLERANCES (UNLESS SPECIFIED) <table border="1"> <tr> <th></th> <th>mm</th> <th>INCH</th> </tr> <tr> <td>4 PLACES</td> <td>± 0.25</td> <td>± 0.010</td> </tr> <tr> <td>3 PLACES</td> <td>± 0.20</td> <td>± 0.008</td> </tr> <tr> <td>2 PLACES</td> <td>± 0.13</td> <td>± 0.005</td> </tr> <tr> <td>1 PLACE</td> <td>± 0.25</td> <td>± 0.010</td> </tr> </table>		mm	INCH	4 PLACES	± 0.25	± 0.010	3 PLACES	± 0.20	± 0.008	2 PLACES	± 0.13	± 0.005	1 PLACE	± 0.25	± 0.010	DIMENSION STYLE MM ONLY DRAWN BY: BBARKER DATE: 2011/11/16 CHECKED BY: DATE:	SCALE: 3:1 DESIGN UNITS: METRIC THIRD ANGLE PROJECTION	TITLE: STACKED SFP+ 2X1 ASS'Y WITH ELASTOMERIC GASKET AND LIGHTPIPES
		mm	INCH																	
	4 PLACES	± 0.25	± 0.010																	
	3 PLACES	± 0.20	± 0.008																	
2 PLACES	± 0.13	± 0.005																		
1 PLACE	± 0.25	± 0.010																		
		APPROVED BY: SMILLER DATE: 2011/11/28 MATERIAL NO.: SEE TABLE DRAFT WHERE APPLICABLE MUST REMAIN WITHIN DIMENSIONS	MOLEX INCORPORATED DOCUMENT NO.: RSD-76090-0001	SHEET NO.: 1 OF 4																
			THIS DRAWING CONTAINS INFORMATION THAT IS PROPRIETARY TO MOLEX INCORPORATED AND SHOULD NOT BE USED WITHOUT WRITTEN PERMISSION																	

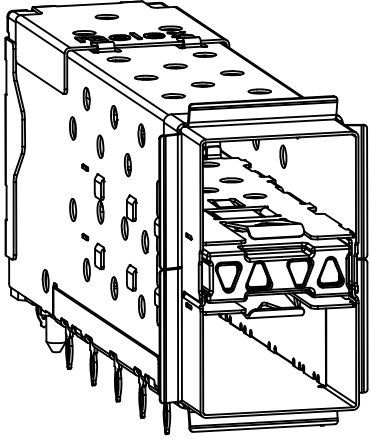

WITH INNER AND OUTER LIGHTPIPES

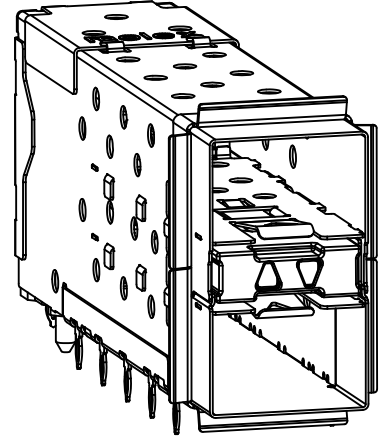

WITH INNER LIGHTPIPES

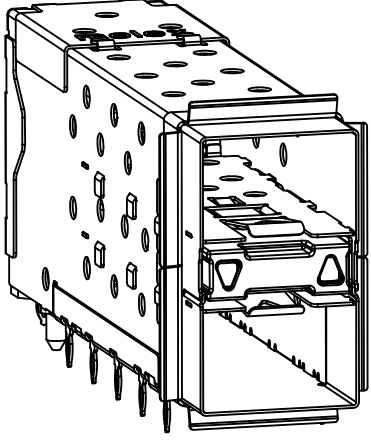

WITH OUTER LIGHTPIPES

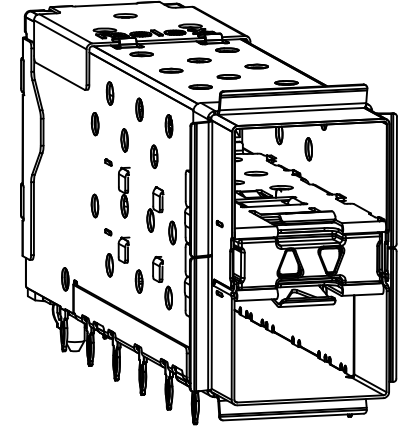

760907002
WITH INNER LIGHTPIPES
& ENHANCED EMI MID-SECTION

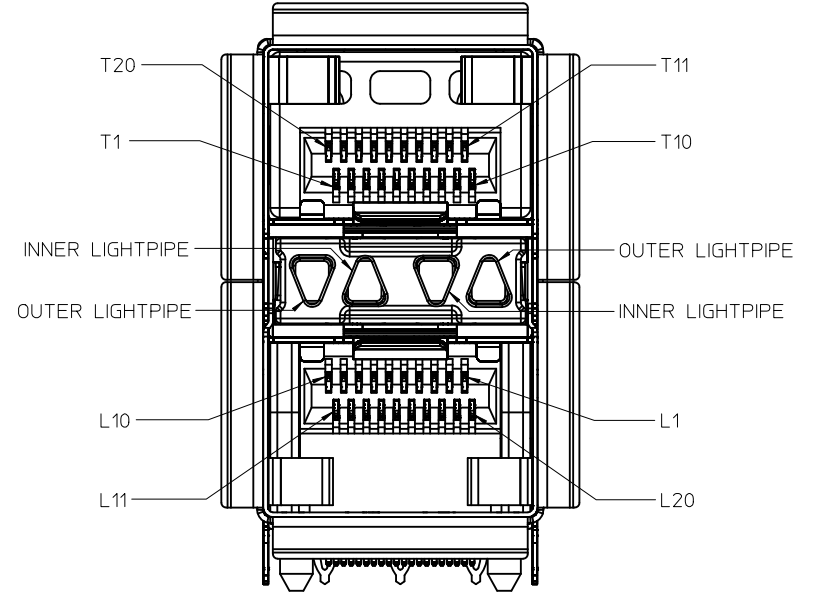

CIRCUIT NUMBERING
AND LIGHTPIPE
IDENTIFICATION

SEE SHEET 1 EC NO: UCP2012-1596 DRWN:BBARKER 2011/11/16 CHKD:JMORGAN APPR:SMILLER 2011/11/28	QUALITY SYMBOLS	GENERAL TOLERANCES (UNLESS SPECIFIED)	DIMENSION STYLE	SCALE	DESIGN UNITS	THIRD ANGLE PROJECTION
	▽=0	mm INCH	MM ONLY	3:1	METRIC	
	▽=0	4 PLACES ± --- ± ---	DRAWN BY DATE	TITLE	STACKED SFP+ 2X1 ASS'Y WITH ELASTOMERIC GASKET AND LIGHTPIPES	
	▽=0	3 PLACES ± --- ± ---	BBARKER 2011/11/16	CHECKED BY DATE	MOLEX INCORPORATED	
		2 PLACES ± 0.13 ± ---	APPROVED BY DATE	DOCUMENT NO.		SHEET NO.
		1 PLACE ± 0.25 ± ---	SMILLER 2011/11/28	RSD-76090-0001		2 OF 4
		ANGULAR ± 5 °	MATERIAL NO.	THIS DRAWING CONTAINS INFORMATION THAT IS PROPRIETARY TO MOLEX INCORPORATED AND SHOULD NOT BE USED WITHOUT WRITTEN PERMISSION		
		DRAFT WHERE APPLICABLE MUST REMAIN WITHIN DIMENSIONS	SEE TABLE, SHT 1			

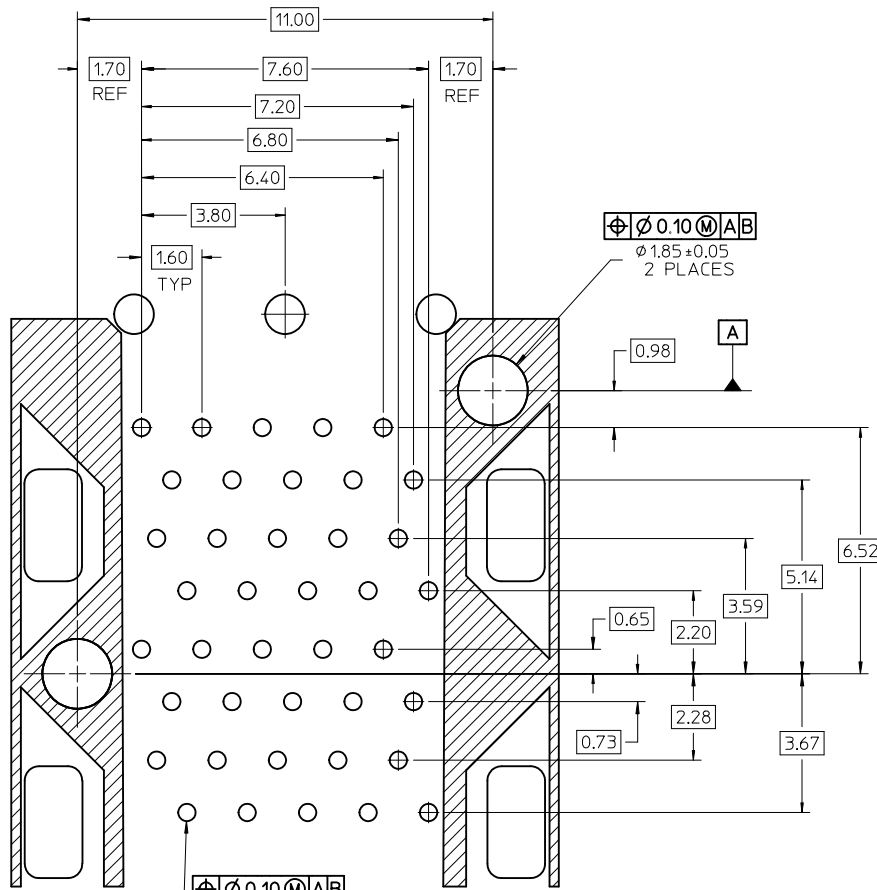

DETAIL A
SCALE 10:1

⊕ ⌀ 0.10 (M) A/B
 ⌀ 0.46 ± 0.05 TYP
 (⌀ 0.57 DRILL)
 (⌀ 0.88 PAD)

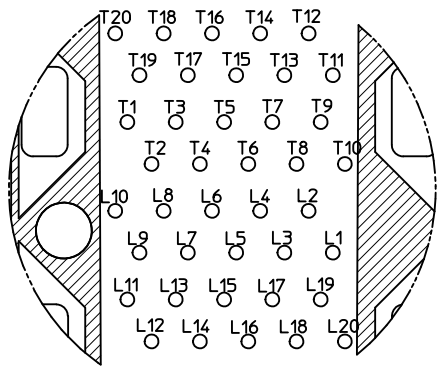

CIRCUIT NUMBERING
 COMPONENT SIDE OF BOARD
 SCALE 10:1

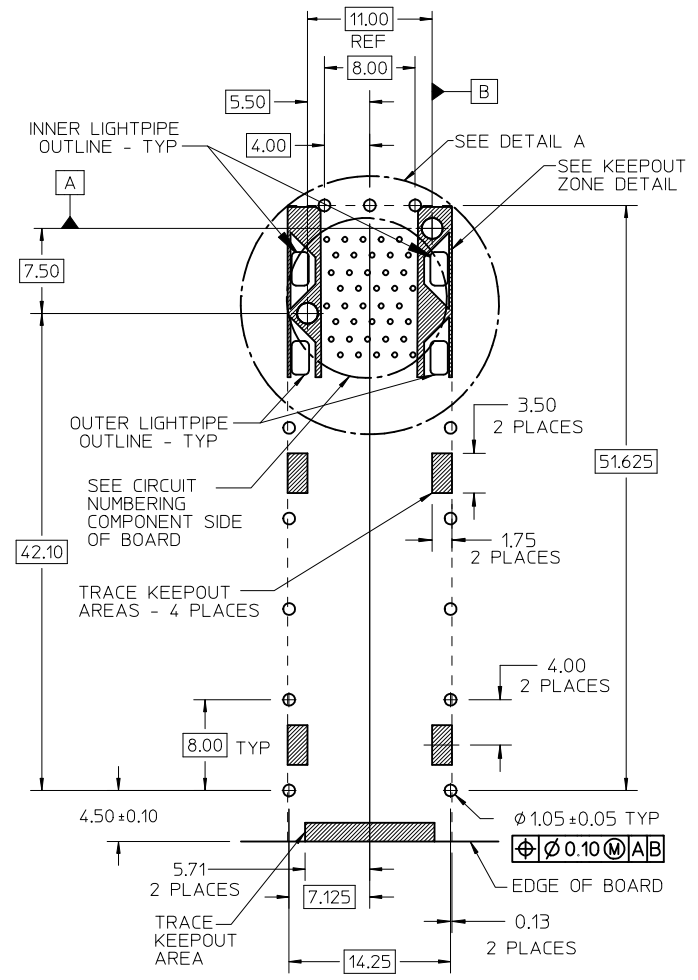

RECOMMENDED PCB LAYOUT - COMPONENT SIDE
 RECOMMENDED PCB THICKNESS - 2.36 MM (.093 INCH)
 THE ENTIRE AREA OF THE CONNECTOR FOOTPRINT
 TO BE CONSIDERED THE KEEP OUT AREA FOR COMPONENTS
 (OTHER THAN LIGHTPIPE LED'S)
 THIS AREA IS INDICATED BY THE DASHED LINE

SEE SHEET 1 EC NO: UCP2012-1596 DRWN:BBARKER 2011/11/16 CHKD:DMORGAN APPR:SMILLER 2011/11/28	QUALITY SYMBOLS ▽=0 ▽=0 ▽=0	GENERAL TOLERANCES (UNLESS SPECIFIED)		DIMENSION STYLE MM ONLY		SCALE 3:1	DESIGN UNITS METRIC	THIRD ANGLE PROJECTION			
		4 PLACES ± --- ± ---	3 PLACES ± --- ± ---	mm	INCH	DRAWN BY BBARKER	DATE 2011/11/16	STACKED SFP+ 2X1 ASS'Y WITH ELASTOMERIC GASKET AND LIGHTPIPES			
		2 PLACES ± 0.13 ± ---	1 PLACE ± 0.25 ± ---			CHECKED BY	DATE				
		ANGULAR ± 5 °		DRAFT WHERE APPLICABLE MUST REMAIN WITHIN DIMENSIONS		APPROVED BY SMILLER		DATE 2011/11/28	MOLEX INCORPORATED		
A	REV	MATERIAL NO. SEE TABLE, SHT 1		MATERIAL NO.		DOCUMENT NO. RSD-76090-0001	SHEET NO. 3 OF 4				

THIS DRAWING CONTAINS INFORMATION THAT IS PROPRIETARY TO MOLEX INCORPORATED AND SHOULD NOT BE USED WITHOUT WRITTEN PERMISSION

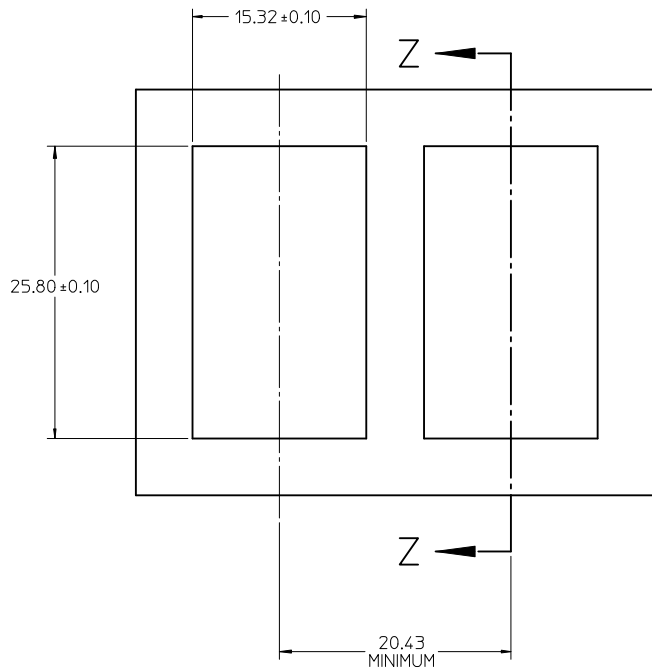

BEZEL CUT-OUT CENTER SPACING DETAIL
BEZEL THICKNESS 0.8-2.6

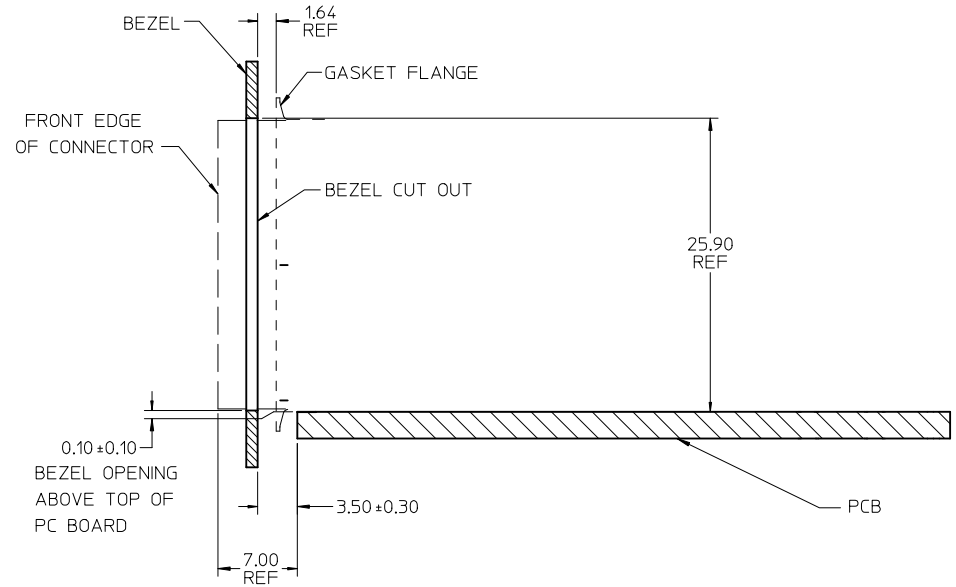

SECTION Z-Z

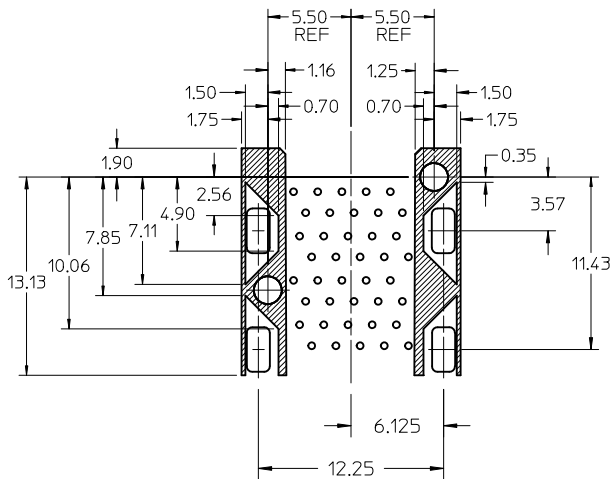

KEEP-OUT ZONE DETAIL - LIGHTPIPE LOCATION AND OTHER ZONES
SCALE 4:1

THE HATCHED AREA IN THIS VIEW INDICATES ZONES THAT ARE OCCUPIED BY THE PLASTIC HOUSING THAT SEATS AGAINST THE PCB AND BY THE VERTICAL METAL CAGE WALL THAT STOPS JUST SHORT OF THE PCB

SEE SHEET 1 EC NO: UCP2012-1596 DRAWN BY: BBARKER 2011/11/16 CHKD BY: JORGAN APPR: SMILLER 2011/11/28	QUALITY SYMBOLS ▽=0 ▽=0 ▽=0	GENERAL TOLERANCES (UNLESS SPECIFIED)		DIMENSION STYLE MM ONLY	SCALE 3:1	DESIGN UNITS METRIC	THIRD ANGLE PROJECTION	
		4 PLACES ± ---	± ---	DRAWN BY BBARKER	DATE 2011/11/16	TITLE STACKED SFP+ 2X1 ASS'Y WITH ELASTOMERIC GASKET AND LIGHTPIPES		
A	REV	3 PLACES ± ---	± ---	CHECKED BY	DATE	APPROVED BY SMILLER		
		2 PLACES ± 0.13	± ---	DATE 2011/11/28		DOCUMENT NO. MOLEX INCORPORATED		
		1 PLACE ± 0.25	± ---	MATERIAL NO.		SHEET NO.		
		ANGULAR ± 5 °		SEE TABLE, SHT 1		RSD-76090-0001		
		DRAFT WHERE APPLICABLE MUST REMAIN WITHIN DIMENSIONS		SIZE C		THIS DRAWING CONTAINS INFORMATION THAT IS PROPRIETARY TO MOLEX INCORPORATED AND SHOULD NOT BE USED WITHOUT WRITTEN PERMISSION		

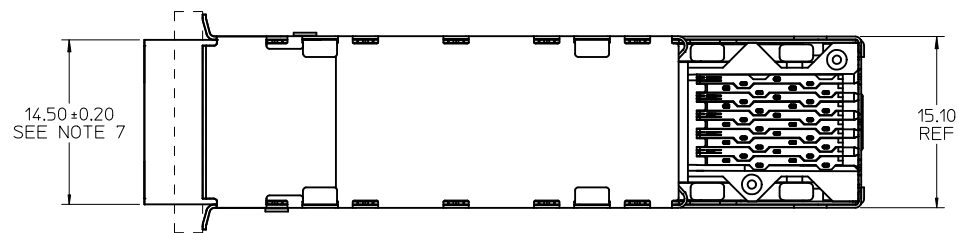
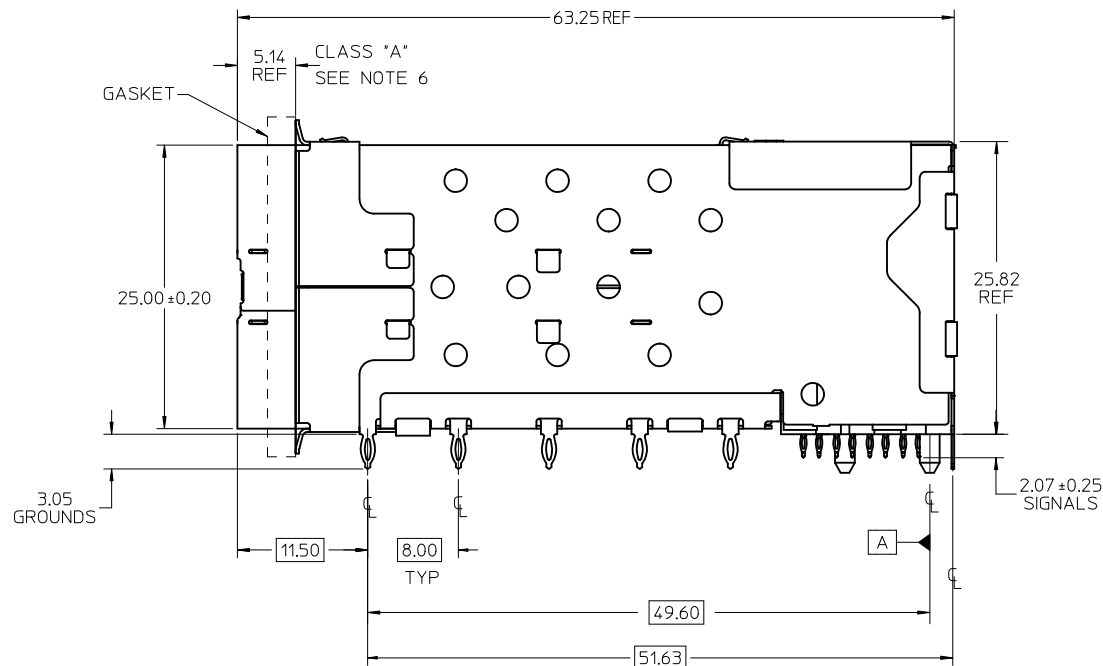
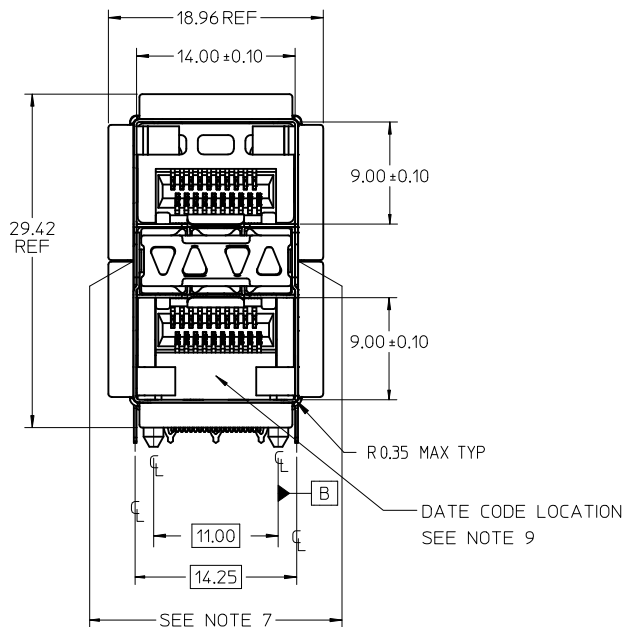

NOTES

- MATERIAL:**
 EMI GASKET: CONDUCTIVE ELASTOMER
 CAGE: NICKEL SILVER, THICKNESS: 0.25mm
 CAGE FLANGE: STAINLESS STEEL
 CONNECTOR HOUSING: GLASS FILLED LIQUID CRYSTAL POLYMER (LCP), UL 94V-0, COLOR: BLACK
 OVERMOLD TERMINAL HOUSING: GLASS FILLED LIQUID CRYSTAL POLYMER (LCP), UL 94V-0, COLOR: BLACK
 TERMINALS: TIN BRASS
 LIGHTPIPES: POLYCARBONITE, 94 V-0, CLEAR
 LIGHTPIPE HOUSING: ZINC
- FINISHES:**
 TERMINALS: CONTACT AREA: 0.76 MICROMETERS MINIMUM HARD GOLD OVER 1.27 MICROMETERS MINIMUM NICKEL.
 COMPLIANT TAIL - TIN/LEAD OPTION: 0.76 TO 1.52 MICROMETERS 90/10 TIN-LEAD OVER 0.76 MICROMETERS MINIMUM NICKEL.
 COMPLIANT TAIL - TIN OPTION: 0.76 TO 1.52 MICROMETERS TIN OVER 0.76 MICROMETERS MINIMUM NICKEL.
 LIGHTPIPE HOUSING: 80 MICROMETERS MINIMUM NICKEL OVER COPPER
- REFER TO PS-75310-001 PRODUCT SPEC FOR ALL ELECTRICAL, MECHANICAL, AND ENVIRONMENTAL SPECIFICATIONS.
- LIGHTPIPE PAD LAYOUT IS FOR 0805 LOW-PROFILE LED PACKAGE, FOR OTHER RECOMMENDED LAYOUTS REFER TO MOLEX'S REPORT TS-75310-001.
- REFER TO PK-75462-001 FOR ALL PACKAGING SPECIFICATIONS.
- ALL EXTERIOR SURFACES TO BE CLASS "B" SURFACE EXCEPT THE UNDER SIDE PF THE CAGE WHERE THE PCB WOULD BE LOCATED AND AS NOTED, THE SURFACES TO CONFORM TO THE MOLEX COSMETIC DOC PS-45499-002.
- THE OVERALL CAGE WIDTH AT THE VERTICAL CENTER OF THE FRONT EDGE WILL FALL WITHIN THIS DIMENSION: 14.75+/-0.30 MM. THIS PORTION OF THE CAGE WILL FLEX INWARD AS THE CAGE IS BEING INSERTED INTO THE BEZEL OPENING.
- REFER TO AS-76090-001 FOR HIGH SPEED ROUTING RECOMMENDATIONS.
- DATE CODE LOCATION IS SHOWN ABOVE.
 DATE CODE FORMAT: DDDY MX A1
 DDD = DAY OF THE YEAR
 Y = YEAR
 MX = MOLEX
 A = ALPHA CHARACTER - INDICATES MANUFACTURING LINE
 1 = NUMERIC CHARACTER - INDICATES PRODUCTION SHIFT

PART NUMBER	DESCRIPTION	VIEW	COMPLIANT TAIL PLATING
760900001	4 LIGHT PORTS	SEE PG 2	TIN / LEAD
760900002	INNER 2 PORTS	SEE PG 2	TIN / LEAD
760900003	OUTER 2 PORTS	SEE PG 2	TIN / LEAD
760905001	4 LIGHT PORTS	SEE PG 2	TIN
760905002	INNER 2 PORTS	SEE PG 2	TIN
760905003	OUTER 2 PORTS	SEE PG 2	TIN
760903002	INNER 2 PORTS	SEE PG 2	TIN / LEAD
760906002	INNER 2 PORTS	SEE PG 2	TIN

ADD -6002 ASSEMBLY EC NO: UCP2011-3362 DRW:WOLFE 2011/02/28 CHK:D:SMART APPR:SMILLER 2011/05/09 REV:	QUALITY SYMBOLS ▽=0 ▽=0 ▽=0	GENERAL TOLERANCES (UNLESS SPECIFIED) <table border="1"> <tr> <th></th> <th>mm</th> <th>INCH</th> </tr> <tr> <td>4 PLACES</td> <td>± ---</td> <td>± ---</td> </tr> <tr> <td>3 PLACES</td> <td>± ---</td> <td>± ---</td> </tr> <tr> <td>2 PLACES</td> <td>± 0.13</td> <td>± ---</td> </tr> <tr> <td>1 PLACE</td> <td>± 0.25</td> <td>± ---</td> </tr> </table> ANGULAR ± 5 °		mm	INCH	4 PLACES	± ---	± ---	3 PLACES	± ---	± ---	2 PLACES	± 0.13	± ---	1 PLACE	± 0.25	± ---	DIMENSION STYLE MM ONLY DRAWN BY DATE J JANTELEZ 10 01-18-2007 CHECKED BY DATE MSANDBERG 01-18-2007 APPROVED BY DATE KREGNIER 01-18-2007 MATERIAL NO. SEE TABLE	SCALE 3:1 DESIGN UNITS METRIC THIRD ANGLE PROJECTION	TITLE STACKED SFP+ 2X1 ASS'Y WITH ELASTOMERIC GASKET AND LIGHTPIPES MOLEX INCORPORATED DOCUMENT NO. SD-76090-001	SHEET NO. 1 OF 4
		mm	INCH																		
	4 PLACES	± ---	± ---																		
	3 PLACES	± ---	± ---																		
2 PLACES	± 0.13	± ---																			
1 PLACE	± 0.25	± ---																			
DRAFT WHERE APPLICABLE MUST REMAIN WITHIN DIMENSIONS		THIS DRAWING CONTAINS INFORMATION THAT IS PROPRIETARY TO MOLEX INCORPORATED AND SHOULD NOT BE USED WITHOUT WRITTEN PERMISSION																			

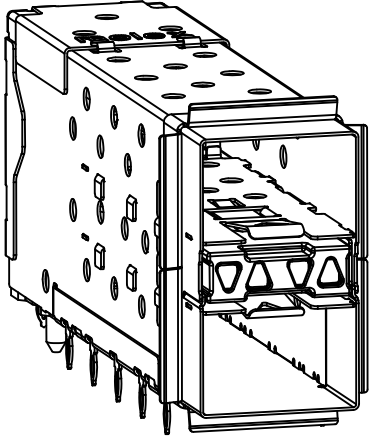

760900001 AND 760905001
WITH INNER AND OUTER LIGHTPIPES

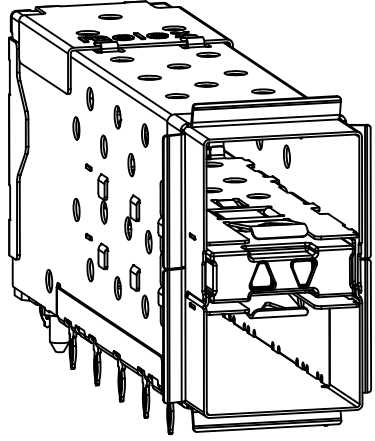

760900002 AND 760905002
WITH INNER LIGHTPIPES

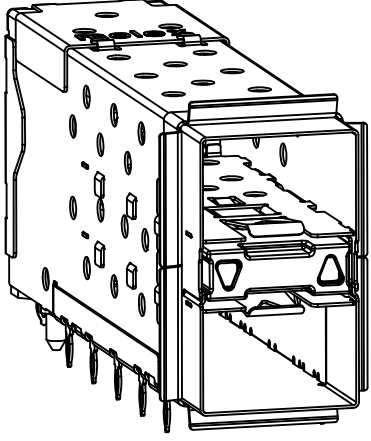

760900003 AND 760905003
WITH OUTER LIGHTPIPES

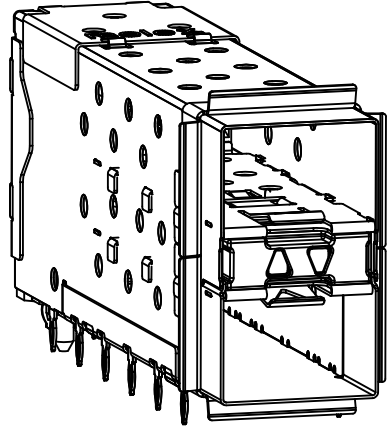

760903002 AND 760906002
WITH INNER LIGHTPIPES
& ENHANCED EMI MID-SECTION

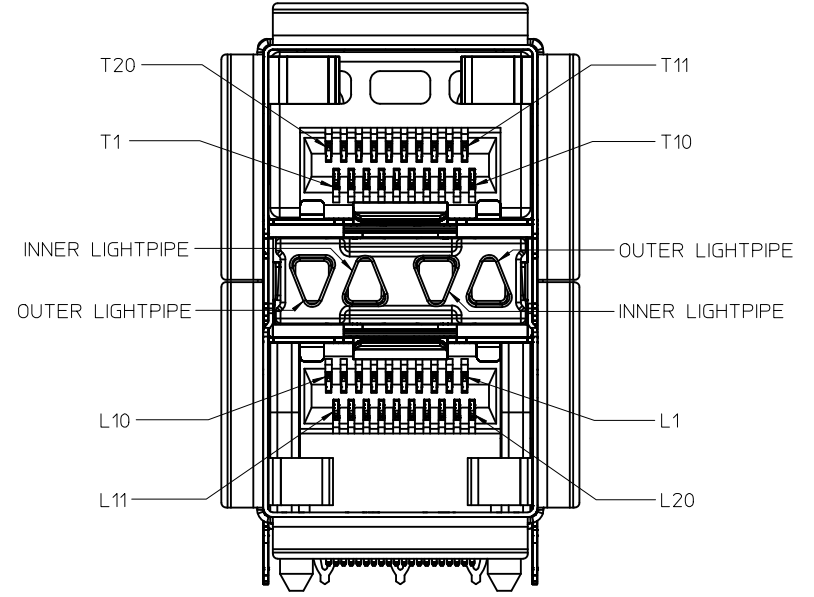

CIRCUIT NUMBERING
AND LIGHTPIPE
IDENTIFICATION

SEE SHEET 1 EC NO: UCP2011-3362 DRW:MMOLFE 2011/02/28 CHK:BSMART APPR:SMILLER 2011/05/09	QUALITY SYMBOLS ▽=0 ▽=0 ▽=0	GENERAL TOLERANCES (UNLESS SPECIFIED) <table border="1"> <thead> <tr> <th></th> <th>mm</th> <th>INCH</th> </tr> </thead> <tbody> <tr> <td>4 PLACES</td> <td>± 0.13</td> <td>± 0.005</td> </tr> <tr> <td>3 PLACES</td> <td>± 0.25</td> <td>± 0.010</td> </tr> <tr> <td>2 PLACES</td> <td>± 0.38</td> <td>± 0.015</td> </tr> <tr> <td>1 PLACE</td> <td>± 0.51</td> <td>± 0.020</td> </tr> </tbody> </table> ANGULAR ± 5°		mm	INCH	4 PLACES	± 0.13	± 0.005	3 PLACES	± 0.25	± 0.010	2 PLACES	± 0.38	± 0.015	1 PLACE	± 0.51	± 0.020	DIMENSION STYLE MM ONLY DRAWN BY DATE JJANTELEZ10 01-18-2007 CHECKED BY DATE MSANDBERG 01-18-2007 APPROVED BY DATE KREGNIER 01-18-2007	SCALE 3:1 DESIGN UNITS METRIC THIRD ANGLE PROJECTION	TITLE STACKED SFP+ 2X1 ASS'Y WITH ELASTOMERIC GASKET AND LIGHTPIPES
		mm	INCH																	
	4 PLACES	± 0.13	± 0.005																	
	3 PLACES	± 0.25	± 0.010																	
2 PLACES	± 0.38	± 0.015																		
1 PLACE	± 0.51	± 0.020																		
DRAFT WHERE APPLICABLE MUST REMAIN WITHIN DIMENSIONS	MATERIAL NO. SEE TABLE	MOLEX INCORPORATED	DOCUMENT NO. SD-76090-001	SHEET NO. 2 OF 4																
THIS DRAWING CONTAINS INFORMATION THAT IS PROPRIETARY TO MOLEX INCORPORATED AND SHOULD NOT BE USED WITHOUT WRITTEN PERMISSION																				

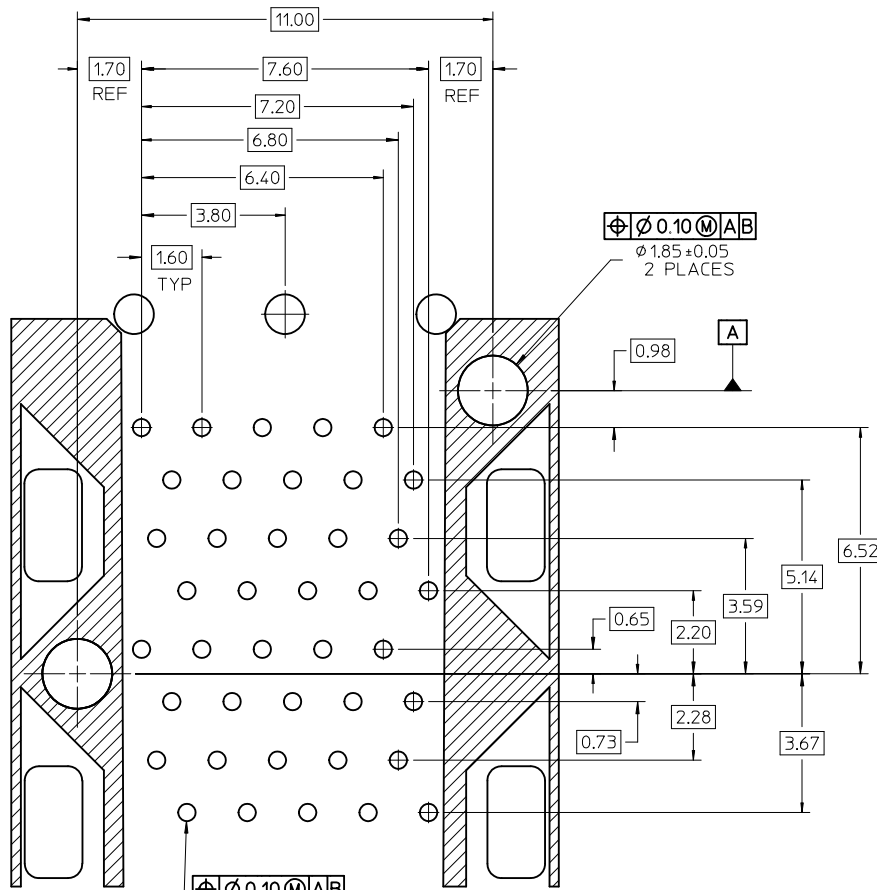

DETAIL A
SCALE 10:1

⊕ ⌀ 0.10 (M) A B
 ⌀ 1.85 ± 0.05
 2 PLACES

⊕ ⌀ 0.10 (M) A B
 ⌀ 0.46 ± 0.05 TYP
 (⌀ 0.57 DRILL)
 (⌀ 0.88 PAD)

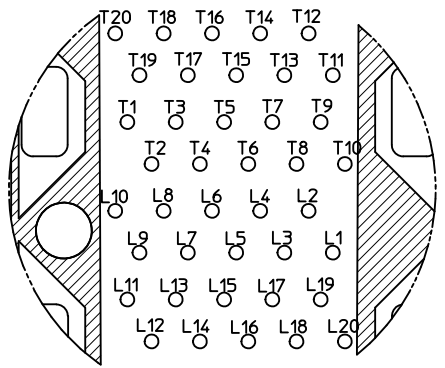

CIRCUIT NUMBERING
 COMPONENT SIDE OF BOARD
 SCALE 10:1

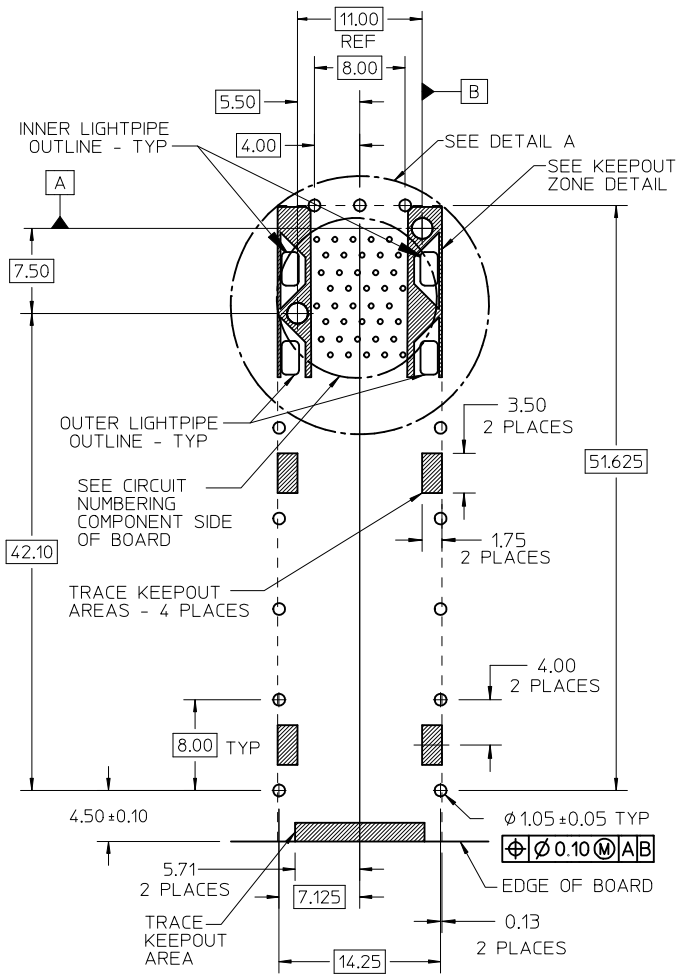

RECOMMENDED PCB LAYOUT - COMPONENT SIDE
 RECOMMENDED PCB THICKNESS - 2.36 MM (.093 INCH)

THE ENTIRE AREA OF THE CONNECTOR FOOTPRINT
 TO BE CONSIDERED THE KEEP OUT AREA FOR COMPONENTS
 (OTHER THAN LIGHTPIPE LED'S)
 THIS AREA IS INDICATED BY THE DASHED LINE

SEE SHEET 1 EC NO: UCP2011-3362 DRWIN:WOLFE 2011/02/28 CHYKD:BSMART APPR:SMILLER 2011/05/09	QUALITY SYMBOLS ▽=0 ▽=0 ▽=0	GENERAL TOLERANCES (UNLESS SPECIFIED)		DIMENSION STYLE MM ONLY		SCALE 3:1	DESIGN UNITS METRIC	THIRD ANGLE PROJECTION	
		4 PLACES ± --- ± --- 3 PLACES ± --- ± --- 2 PLACES ± 0.13 ± --- 1 PLACE ± 0.25 ± --- ANGULAR ± 5 °	mm INCH ± --- ± --- ± --- ± --- ± 0.13 ± --- ± 0.25 ± ---	DRAWN BY JJANTELEZIO	DATE 01-18-2007	CHECKED BY MSANDBERG	DATE 01-18-2007	STACKED SFP+ 2X1 ASS'Y WITH ELASTOMERIC GASKET AND LIGHTPIPES	
DRAFT WHERE APPLICABLE MUST REMAIN WITHIN DIMENSIONS		APPROVED BY KREGNIER		DATE 01-18-2007		MOLEX INCORPORATED			
MATERIAL NO. SEE SHEET 1		DOCUMENT NO. SD-76090-001		SHEET NO. 3 OF 4		THIS DRAWING CONTAINS INFORMATION THAT IS PROPRIETARY TO MOLEX INCORPORATED AND SHOULD NOT BE USED WITHOUT WRITTEN PERMISSION			

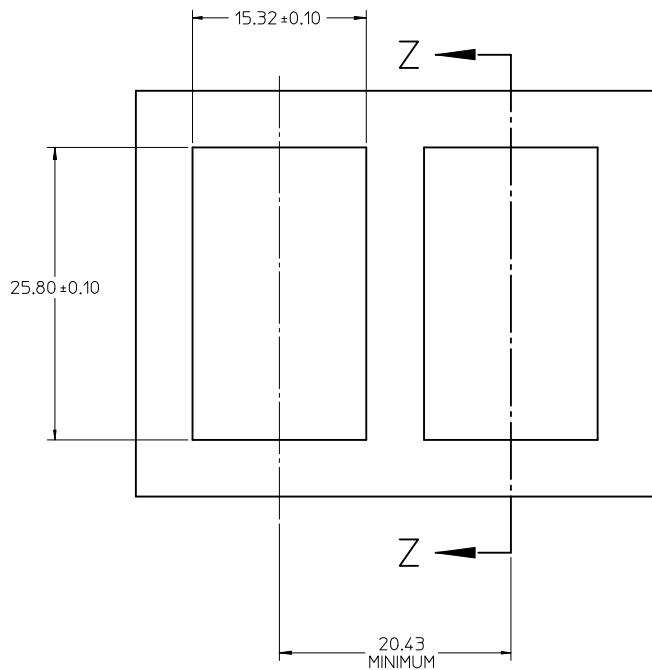

BEZEL CUT-OUT CENTER SPACING DETAIL
BEZEL THICKNESS 0.8-2.6

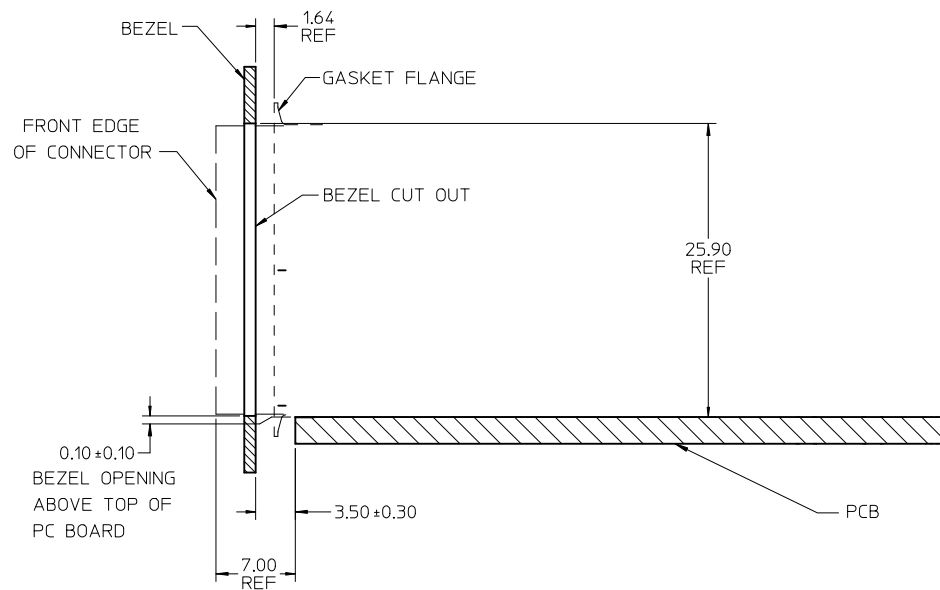

SECTION Z-Z

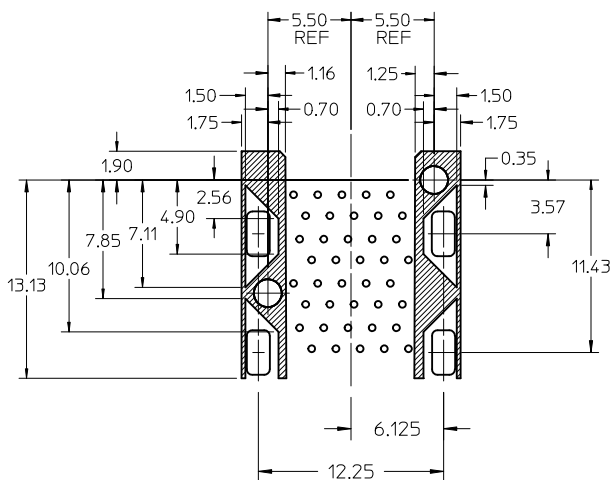

KEEP-OUT ZONE DETAIL - LIGHTPIPE LOCATION AND OTHER ZONES
SCALE 4:1

THE HATCHED AREA IN THIS VIEW INDICATES ZONES THAT ARE OCCUPIED BY THE PLASTIC HOUSING THAT SEATS AGAINST THE PCB AND BY THE VERTICAL METAL CAGE WALL THAT STOPS JUST SHORT OF THE PCB

SEE SHEET 1 EC NO: UCP2011-3362 DRAWN BY: DRWINWOLFE CHKD BY: SMART APPR: SMILLER DATE: 2011/02/28 DATE: 2011/05/09	QUALITY SYMBOLS $\nabla = 0$ $\nabla = 0$ $\nabla = 0$	GENERAL TOLERANCES (UNLESS SPECIFIED) <table border="1"> <thead> <tr> <th></th> <th>mm</th> <th>INCH</th> </tr> </thead> <tbody> <tr> <td>4 PLACES</td> <td>± ---</td> <td>± ---</td> </tr> <tr> <td>3 PLACES</td> <td>± ---</td> <td>± ---</td> </tr> <tr> <td>2 PLACES</td> <td>± 0.13</td> <td>± ---</td> </tr> <tr> <td>1 PLACE</td> <td>± 0.25</td> <td>± ---</td> </tr> </tbody> </table>		mm	INCH	4 PLACES	± ---	± ---	3 PLACES	± ---	± ---	2 PLACES	± 0.13	± ---	1 PLACE	± 0.25	± ---	DIMENSION STYLE MM ONLY DRAWN BY: JJANTELEZ DATE: 01-18-2007 CHECKED BY: MSANDBERG DATE: 01-18-2007 APPROVED BY: KREGNIER DATE: 01-18-2007	SCALE 3:1 DESIGN UNITS METRIC THIRD ANGLE PROJECTION	TITLE STACKED SFP+ 2X1 ASS'Y WITH ELASTOMERIC GASKET AND LIGHTPIPES
		mm	INCH																	
4 PLACES	± ---	± ---																		
3 PLACES	± ---	± ---																		
2 PLACES	± 0.13	± ---																		
1 PLACE	± 0.25	± ---																		
DRAFT WHERE APPLICABLE MUST REMAIN WITHIN DIMENSIONS	MATERIAL NO. SEE SHEET 1	DOCUMENT NO. SD-76090-001	SHEET NO. 4 OF 4																	